

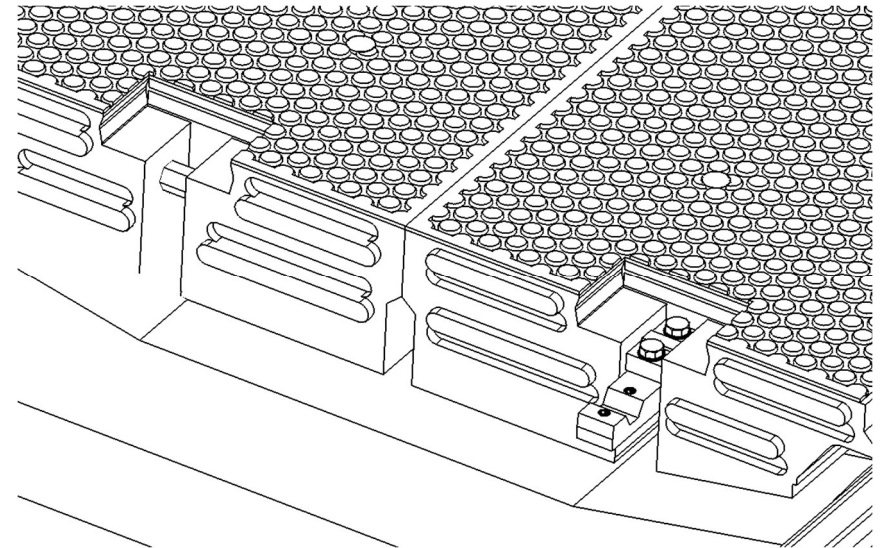

LINK Crossing System



Installation Guide



Rosehill Rail (a Division of Rosehill Polymers Ltd.)

Rosehill Mills

Beech Road

Sowerby Bridge

West Yorkshire

HX6 2JT – ENGLAND

Email : sales@rosehillrail.com

Tel. : +44 (0)1422 839 610

Fax : +44 (0)1422 835 786

NOTES

A series of horizontal dotted lines for taking notes.

1

- Locate the center of the crossing.

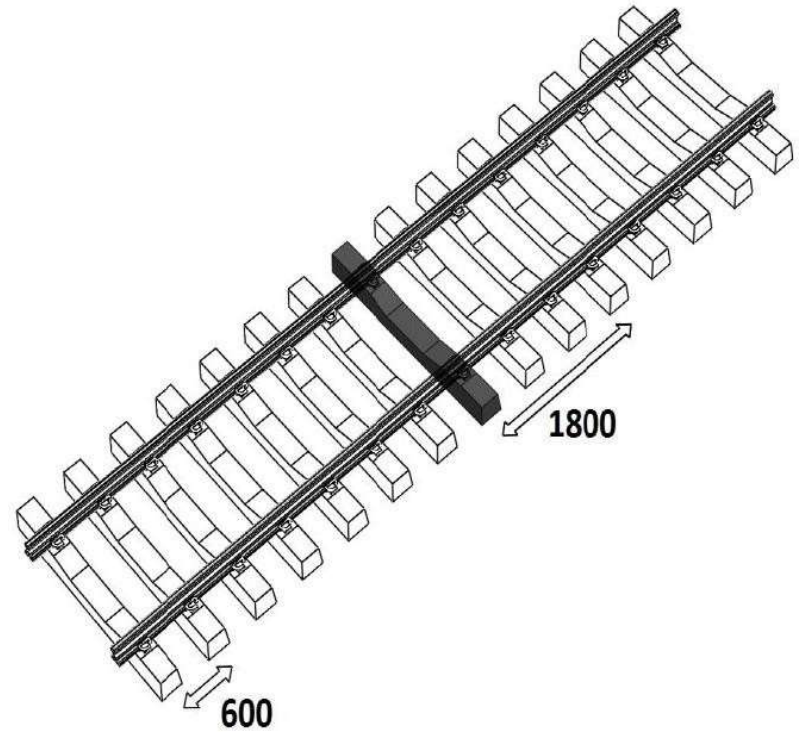

2

- Lift Gauge Panels "A" using Lifting Pins "O", in pairs

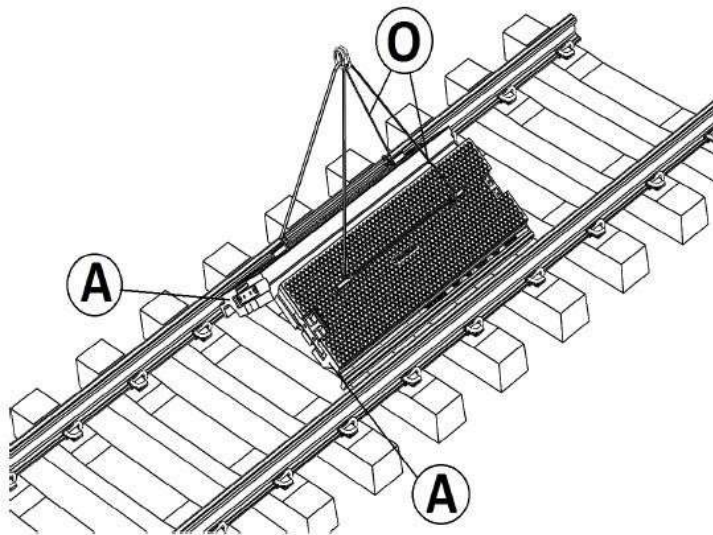

13

- Install the Cover Plate "M" to fill the hole for the LINK Connectors. Install the Rubber Plugs "L" into the Lifting Pin holes.

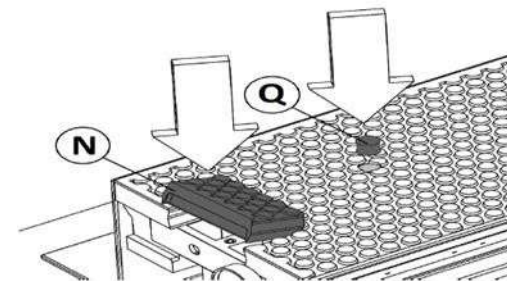
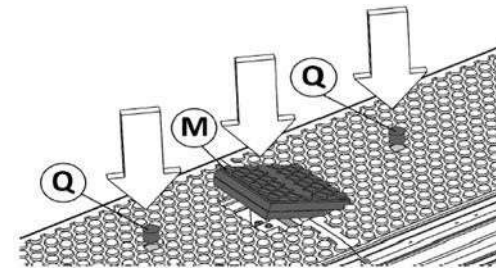

12

- Connect the Chain Guard “F” to each end of the Crossing

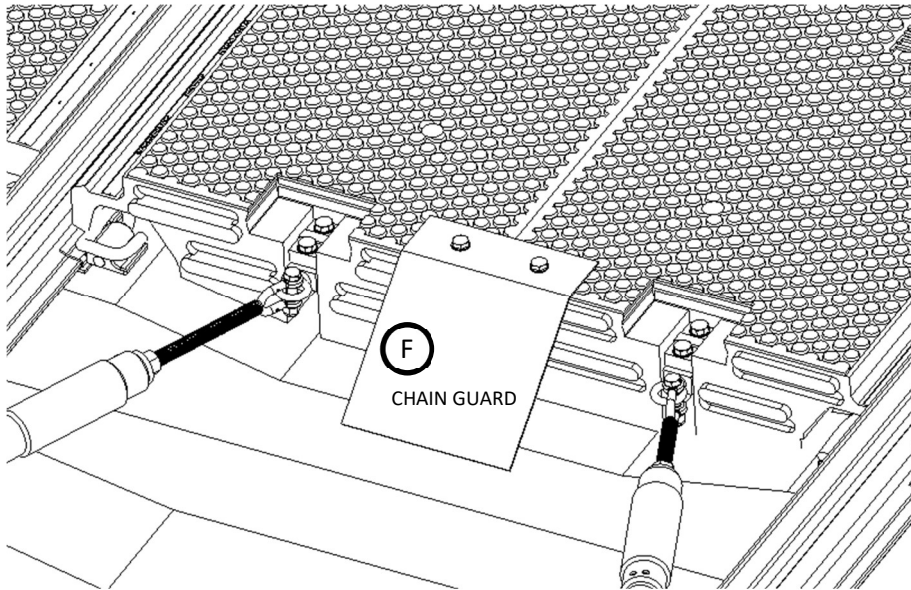

3

- Place gauge panels between rails ensuring panel ends are in the center of the sleeper.

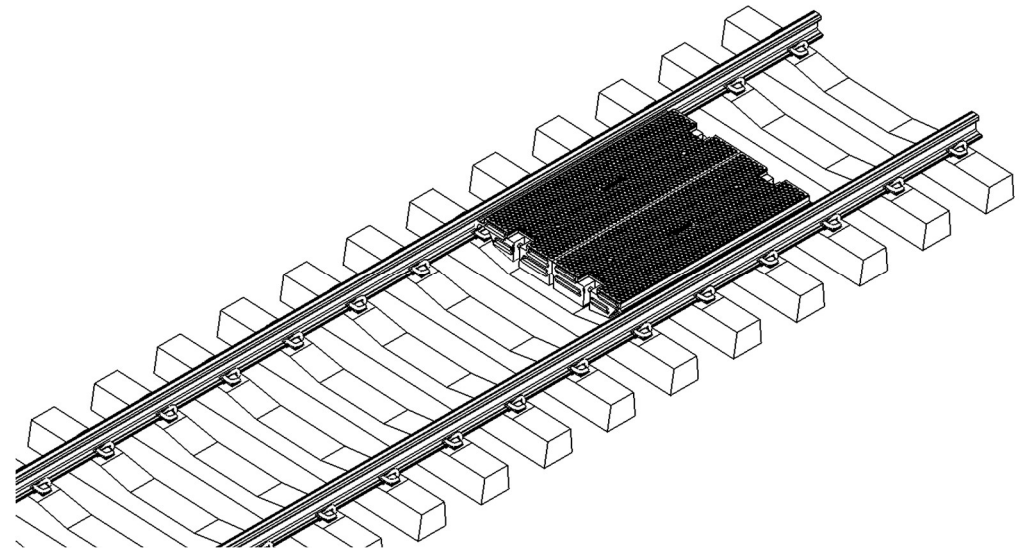

4

- Present the main body of the LINK Connector “G” to the panel

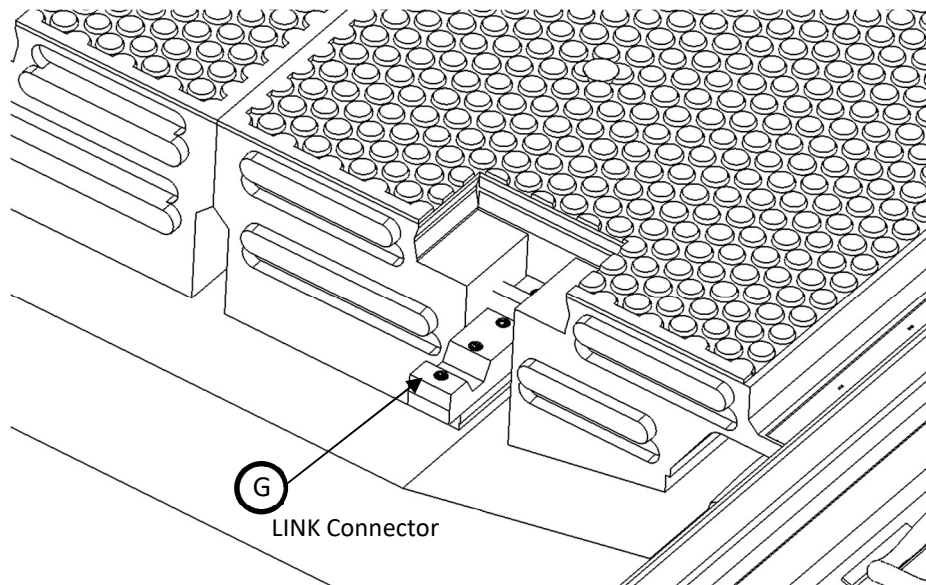

11

- Connect the End Restraint “C” to the LINK End Connector.
- Connect the other end of the End Restraint to the underside of the rail foot using the clamp provided “D” using Bolts “E”.

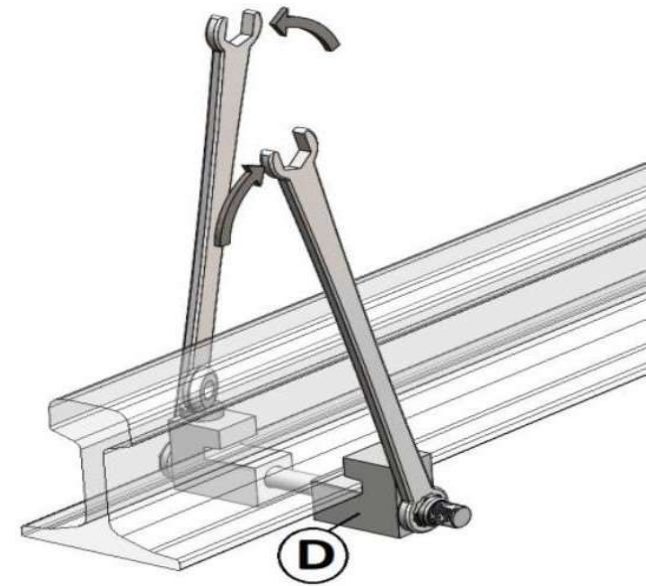

10

- Connect the LINK End Connectors “H” to all the end panels of the crossing.
- Place cover and bolts over the body of the LINK Connector.
- Screw Bolts tight to torque setting 125Nm.

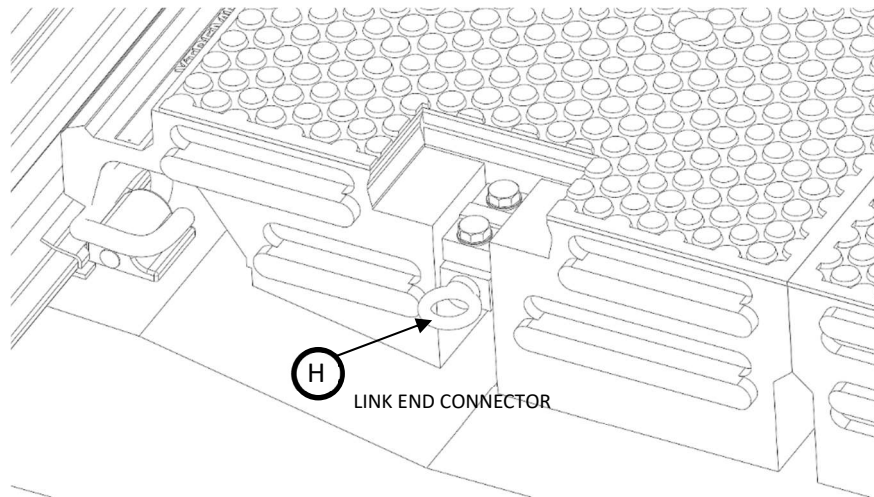

5

Place cover and turn bolts 4-5 turns into the body of the LINK Connector.

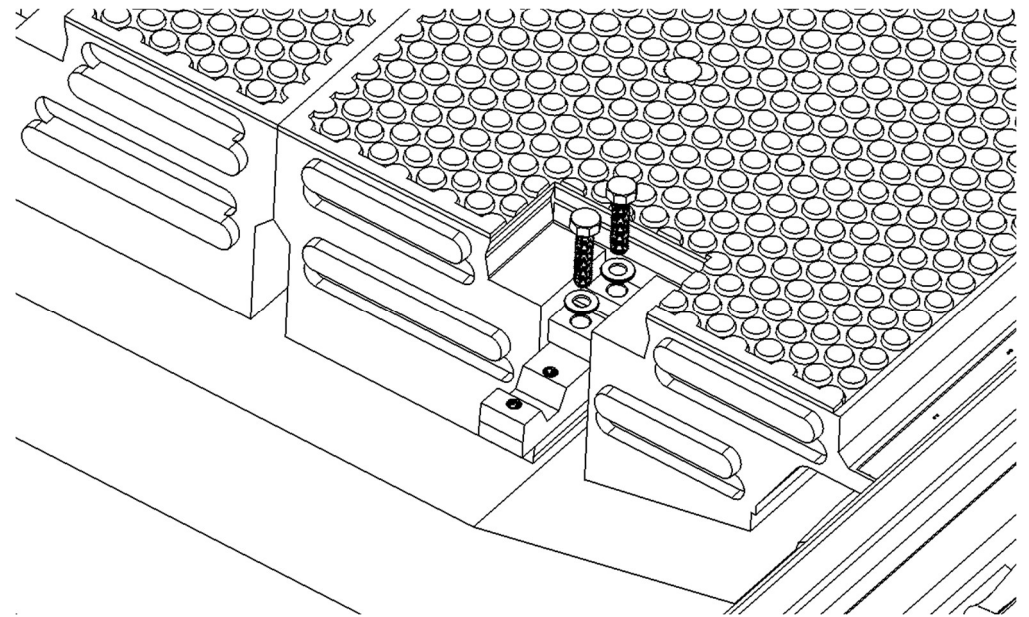

6

- Present the next pair of Gauge Panels onto the main body of the LINK Connector.

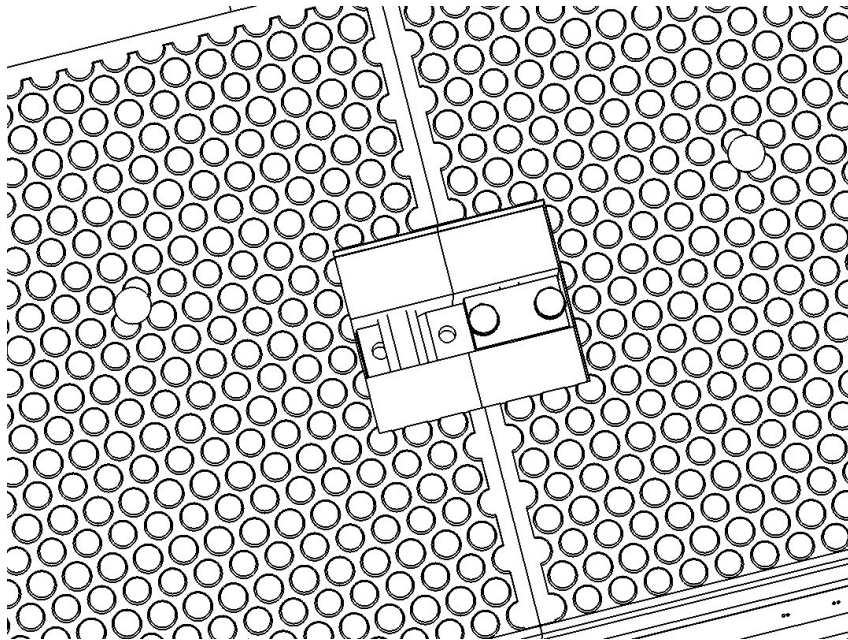

9.c. Rubber Edge Beam with Concrete Sill Beam

- Measure the distance and height for the ≥ 300 mm C50 dry concrete mix to locate the correct positioning of the Concrete Sill Beam and the Rubber Edge Beam.
- Install individually the Field Panels "B" working once again from the center of the crossing, repeating Steps 3 to 5 until all the Field Panels of the crossing have been installed.

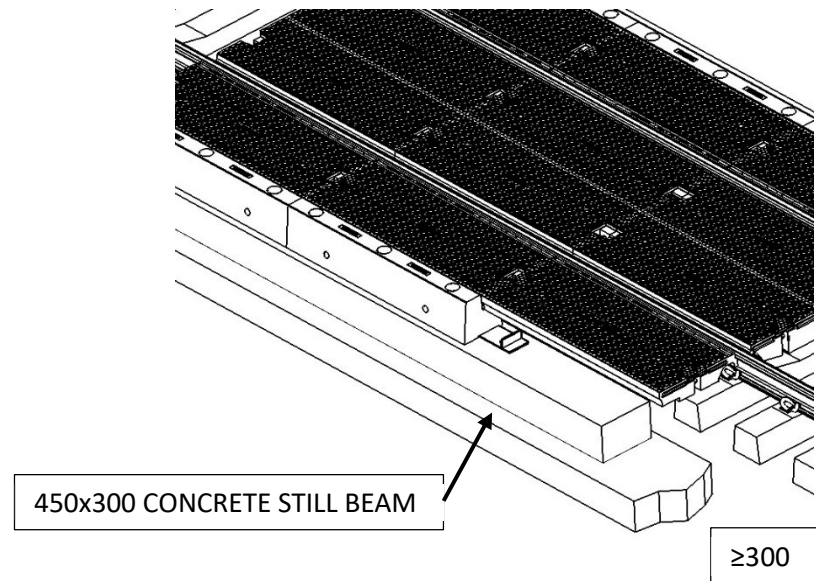

9.b. Rubber Edge Beam

- Measure the distance and height for the $\geq 300\text{mm}$ C50 dry concrete mix to locate the correct positioning of the Rubber Edge Beam.
- Install individually the Field Panels “B” working once again from the center of the crossing, repeating Steps 3 to 5 until all the Field Panels of the crossing have been installed.

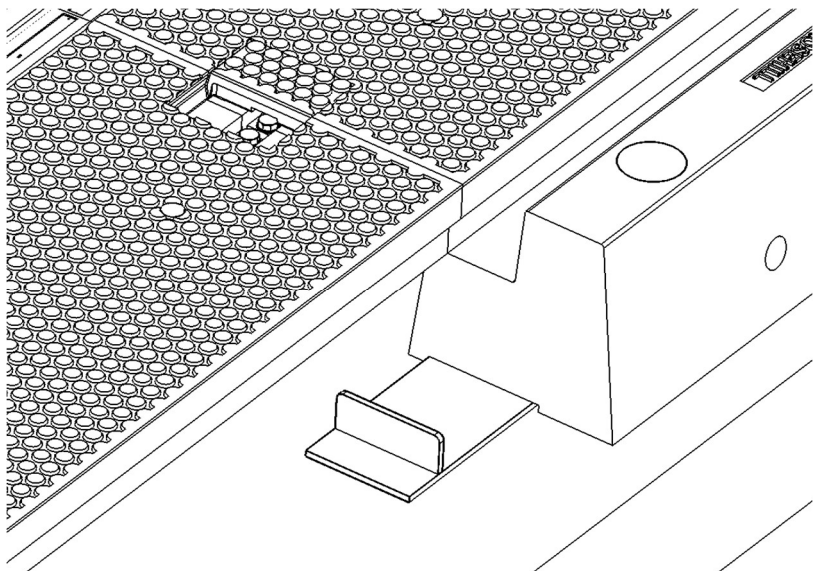

1. Place cover and bolts over the body of the LINK Connector.
2. Place the remaining cover and x2 bolts over the body of the LINK Connector.
3. Tighten each bolt 5-6 turns before moving to the next in order of 1, 3, 2, 4
4. Tighten all 4 Bolts to Torque Setting 300Nm

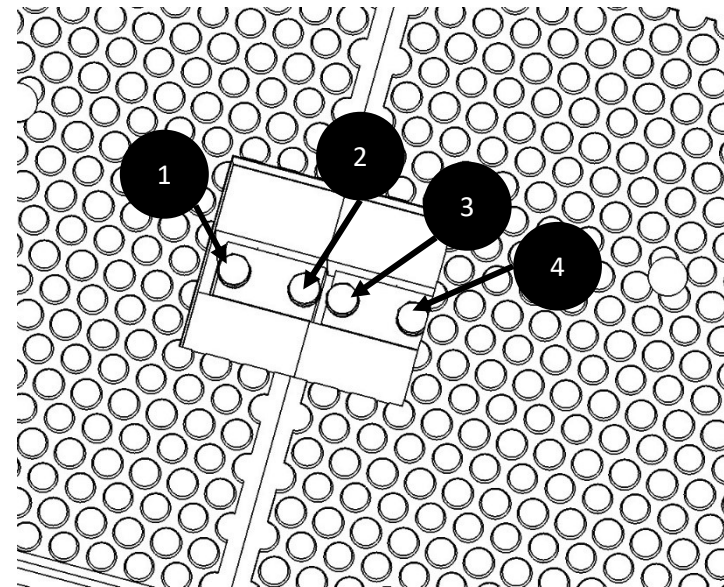

8

- Repeat Steps 3 to 5 until all the Gauge panels of the crossing have been installed.
- Prepare the ground for the Edge Beams, recommended 300mm compacted dry mix concrete.

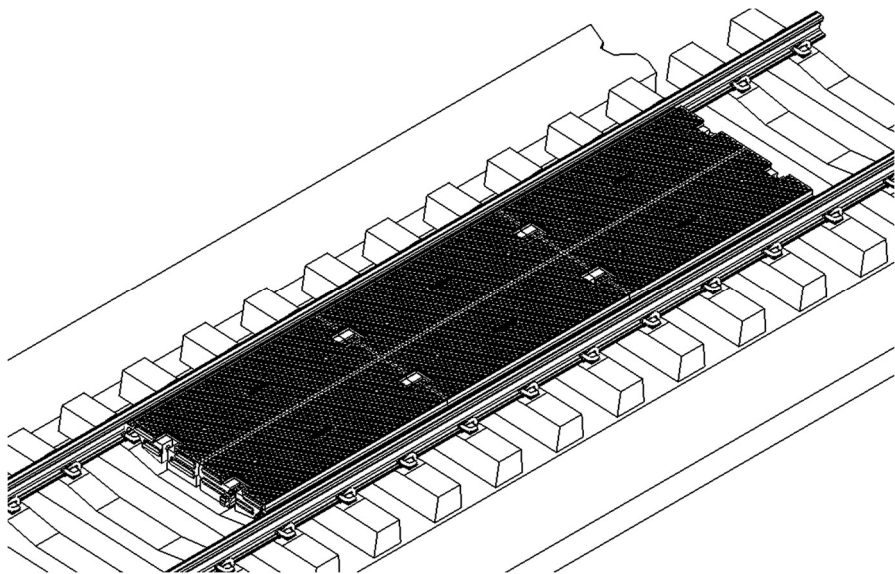

9

Plastic and / or Steel Edge Beams

- Install individually the Field Panels “B” working once again from the center of the crossing, repeating Steps 3 to 5 until all the Field Panels of the crossing have been installed.
- Pack C50 dry concrete mix to the correct height for the Edge Beam
- **9.a.1 - Plastic Edge Beams** Screw the Plastic Edge Beams to the sides of the panels and fill with dry mix concrete.
- **9.a.2 - Steel Edge Beams** Push the Steel Edge Beam against the Field Panels and fill with dry mix concrete.

