

Connect Crossing System

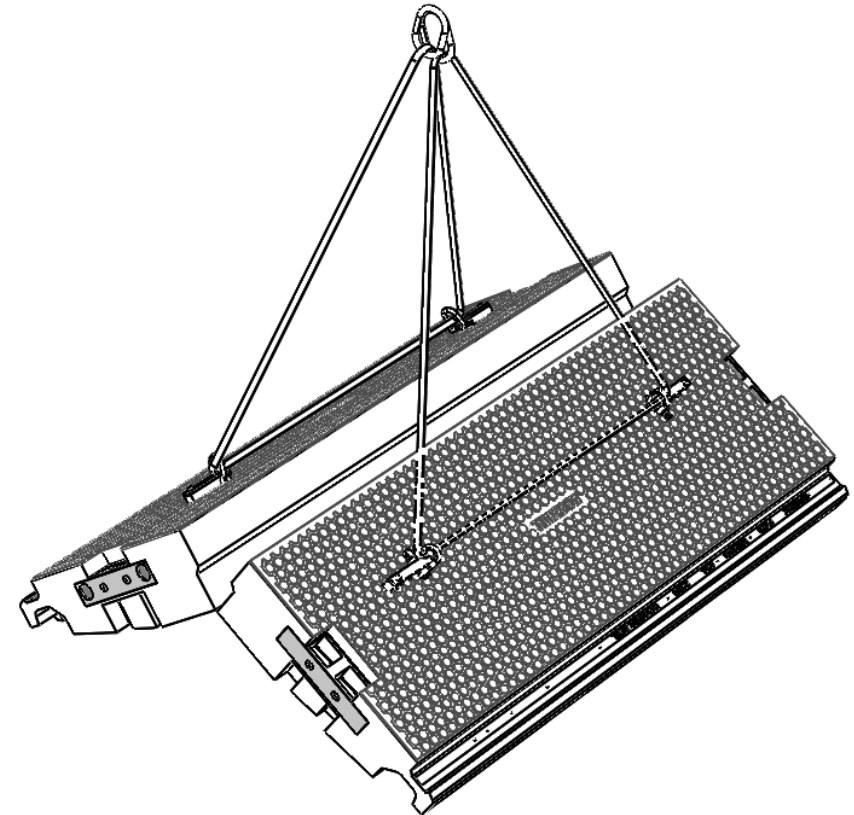
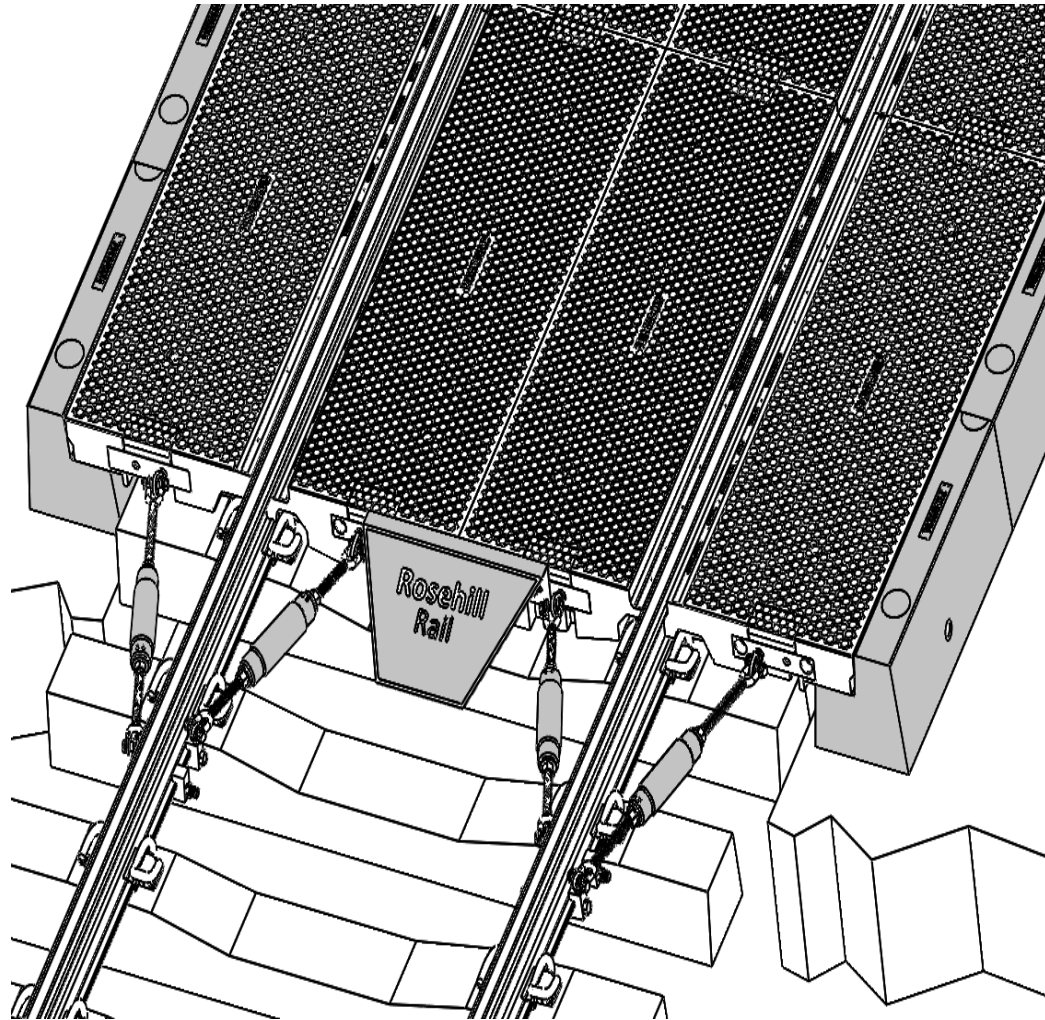

Installation Guide

Tel.+44 (0)1422 839610

E-mail. sales@rosehillrail.com

Version : 23.10 V7.0

rosehillrail.com



RODDED COMPONENTS LIST.

12

PANELS

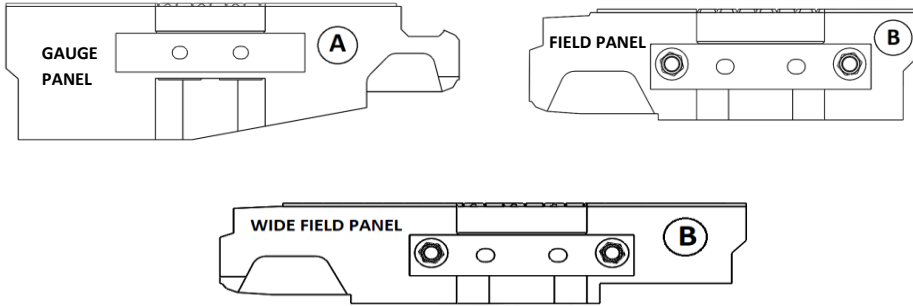

END RESTRAINT & RAIL CLAMP KIT

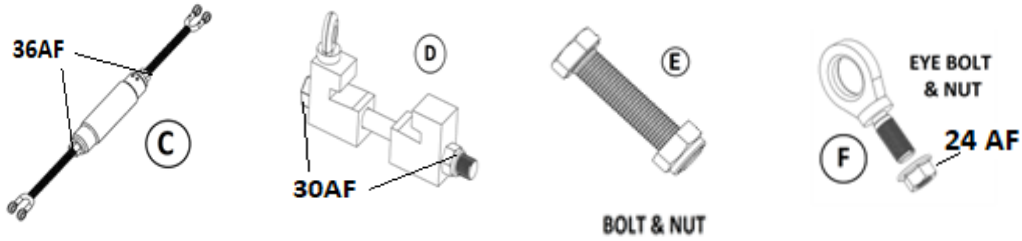

MOVEMENT RESTRICTOR

CHAIN GUARD

FIXING BOLTS WITH WASHERS ASSEMBLED

(CHAIN GUARD & PANELS)

Copper Grease required and supplied

H1

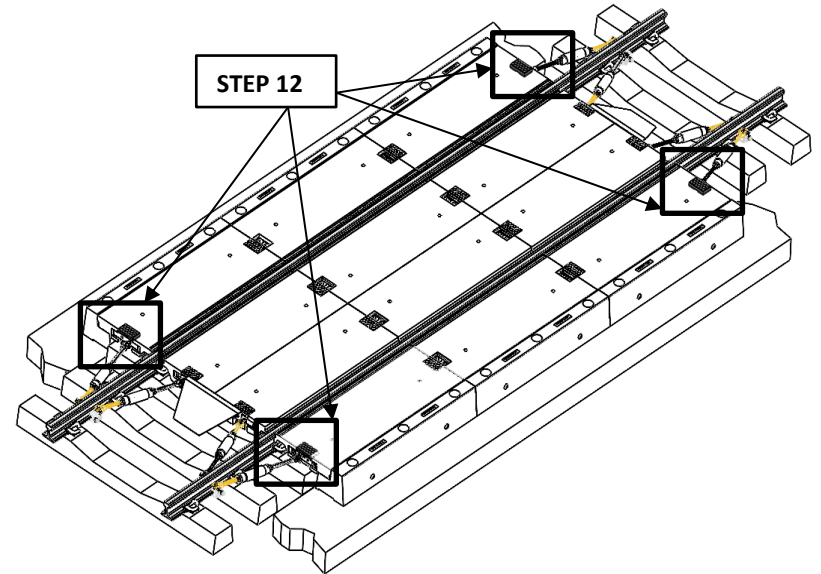
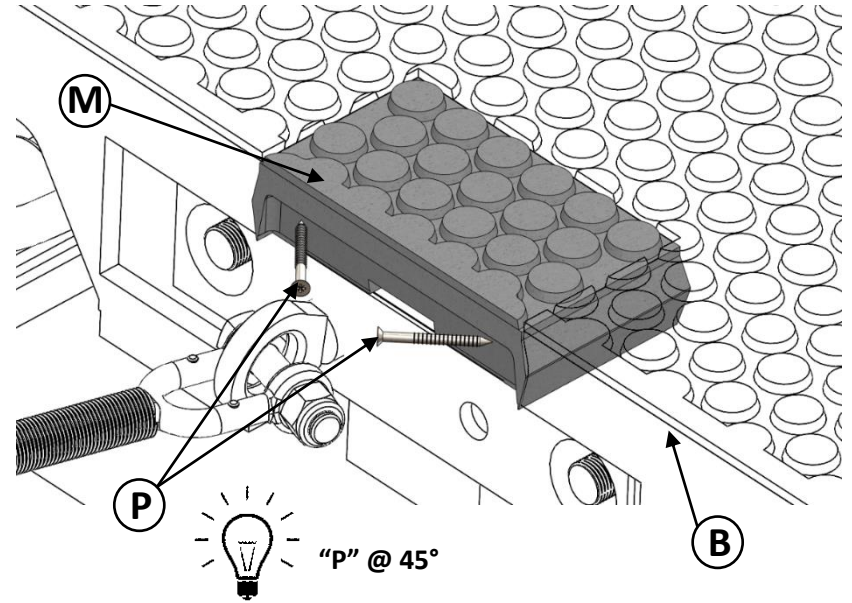
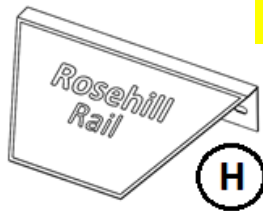
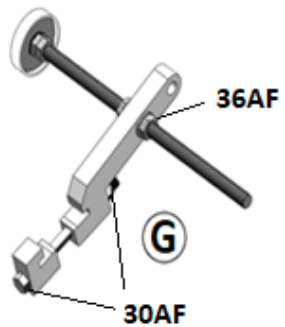

10

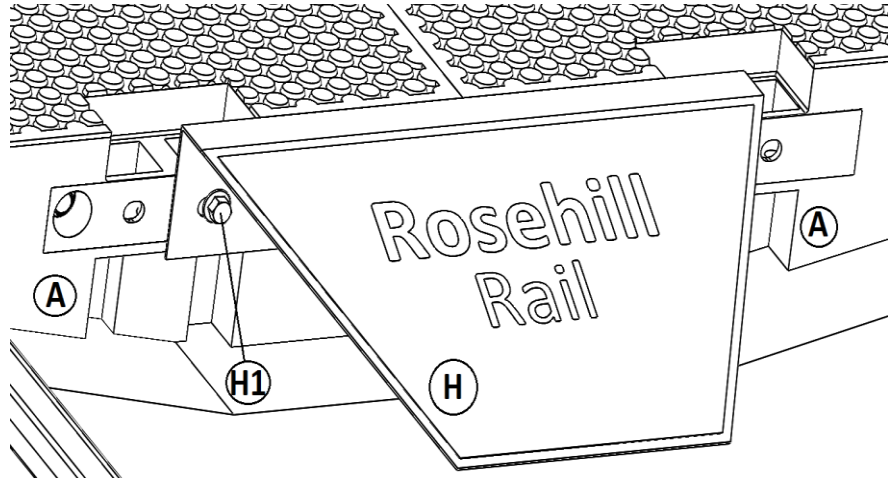

EDGE BEAMS

RUBBER & CONNECTING PLATE

STEEL 250 X 250

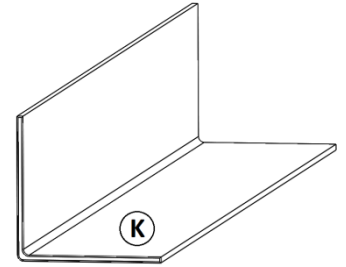
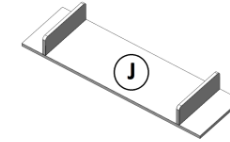
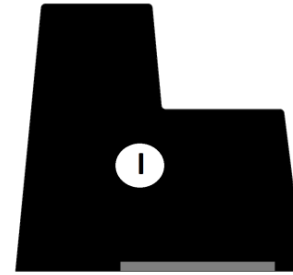

RUBBER PLUG

COVER PLATE

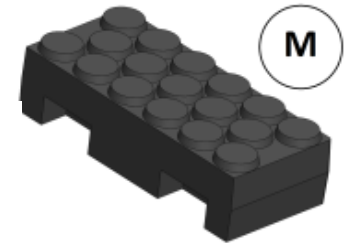
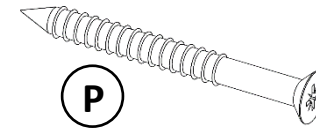
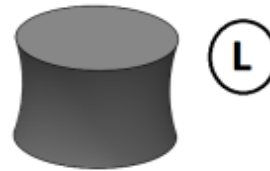

WOOD SCREW

LIFTING PIN KIT

TOOL KIT (OPTIONAL)



27AF

27AF

11

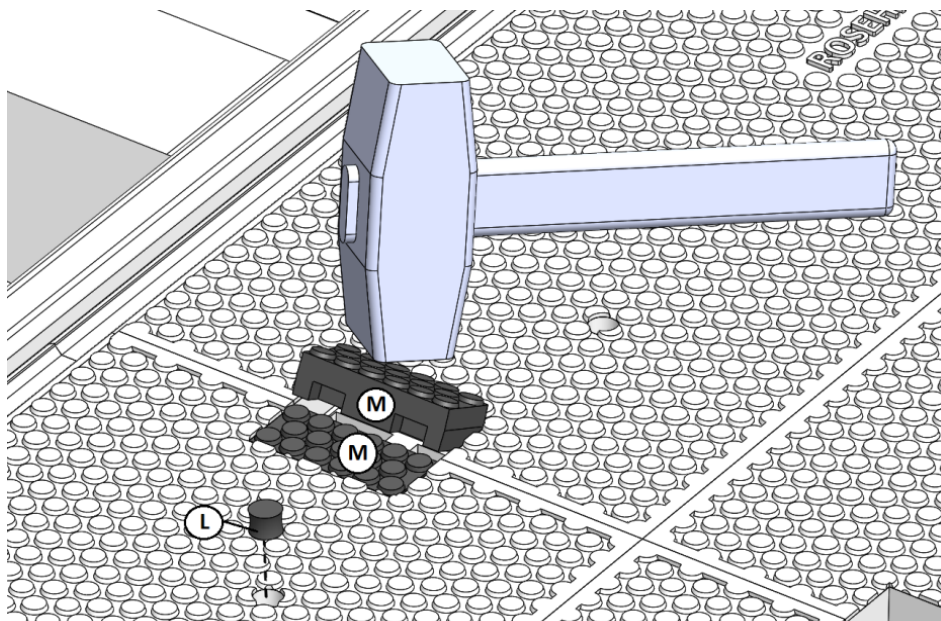

1

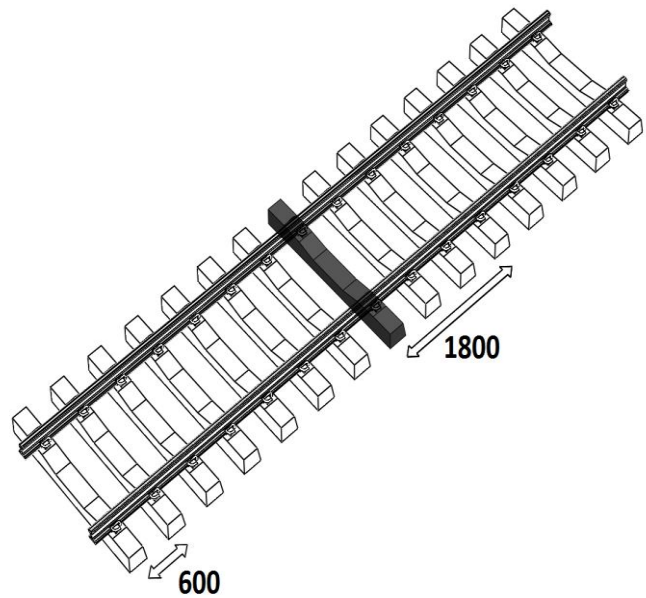

2

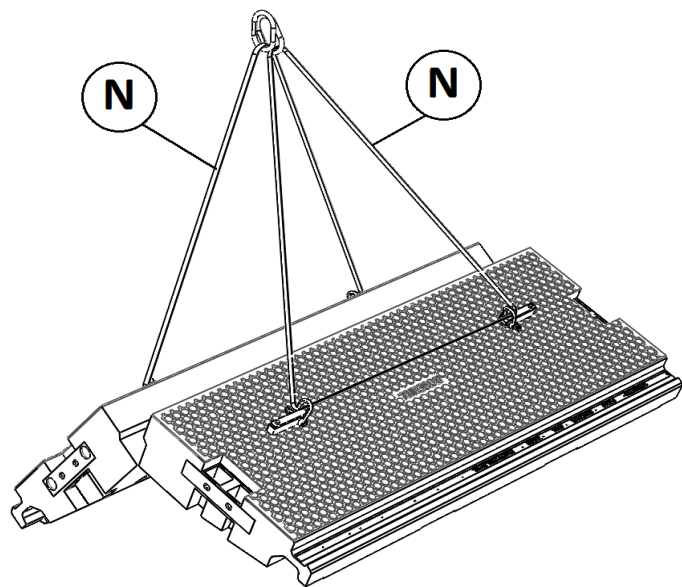

8b

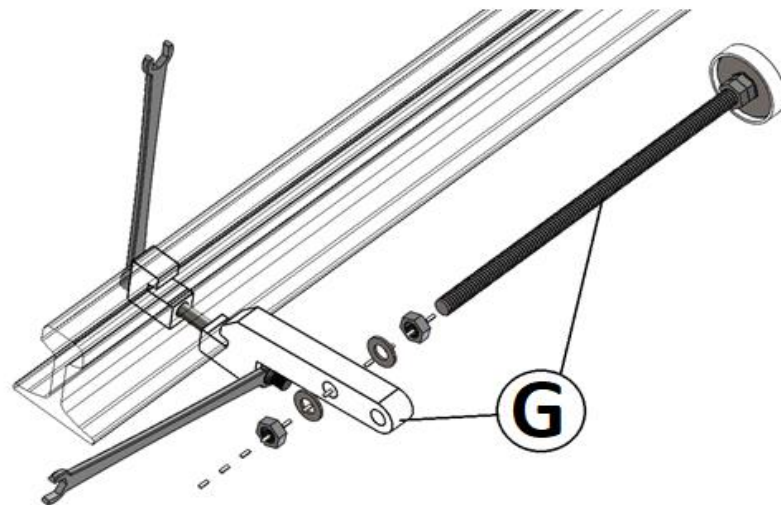

9b

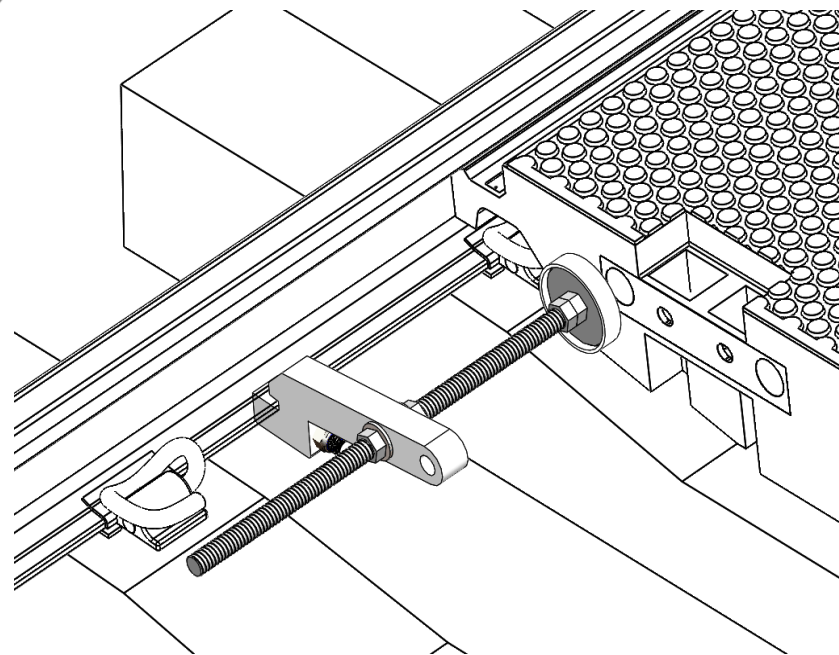

8a

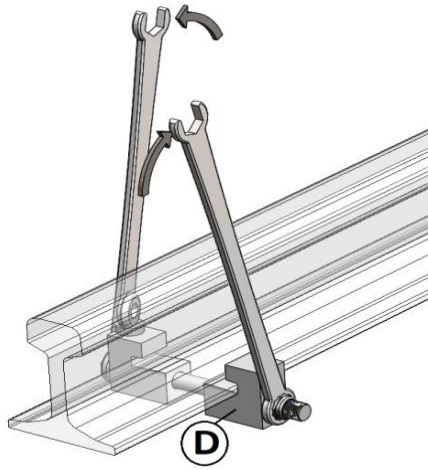

3

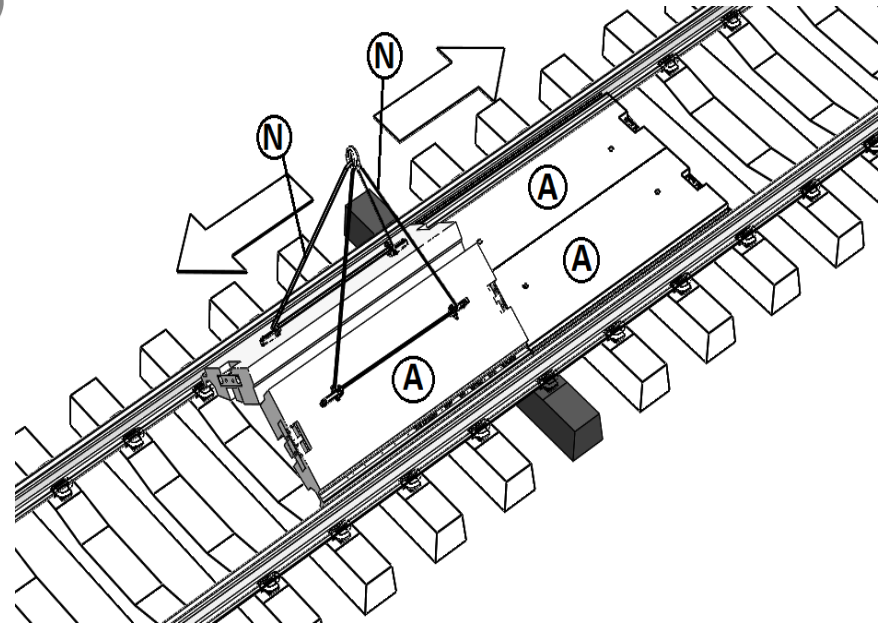

9a

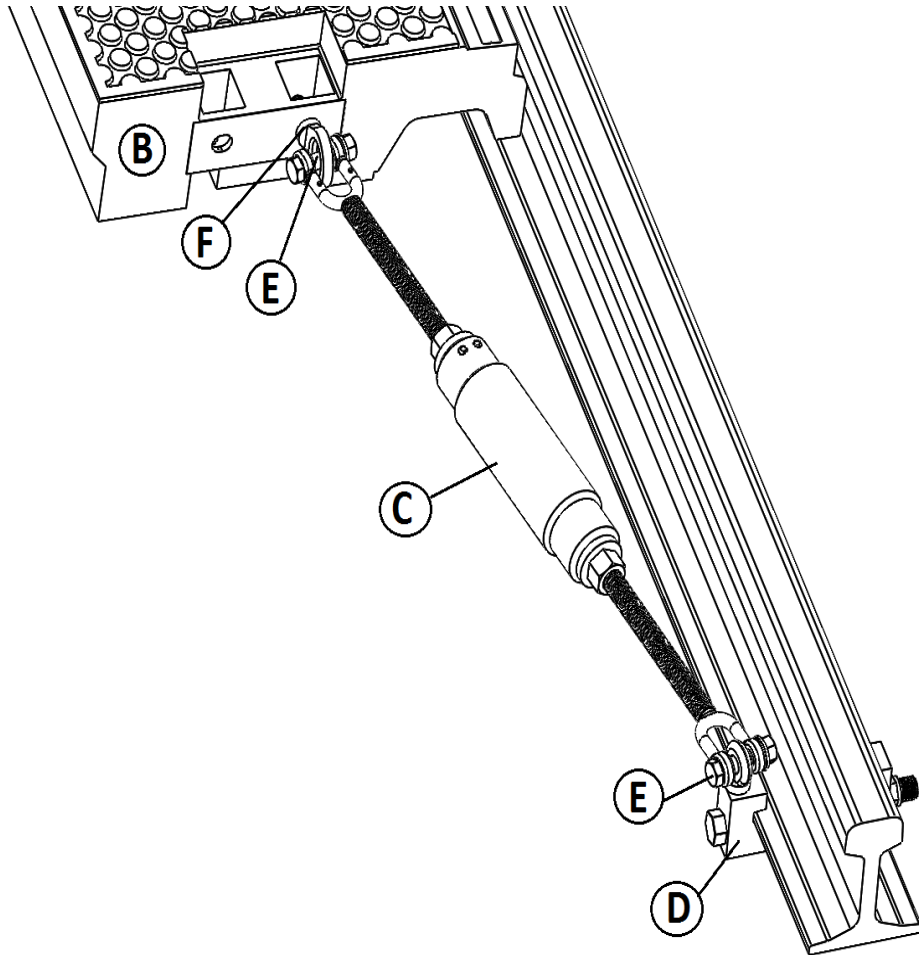

4A

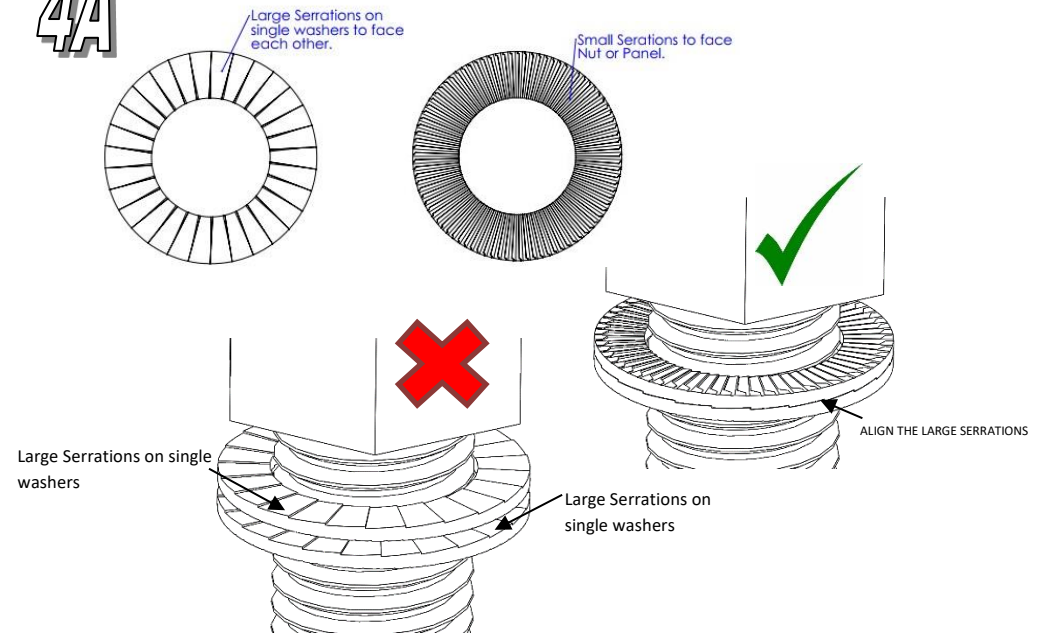

4B



Apply copper grease to each bolt assembly

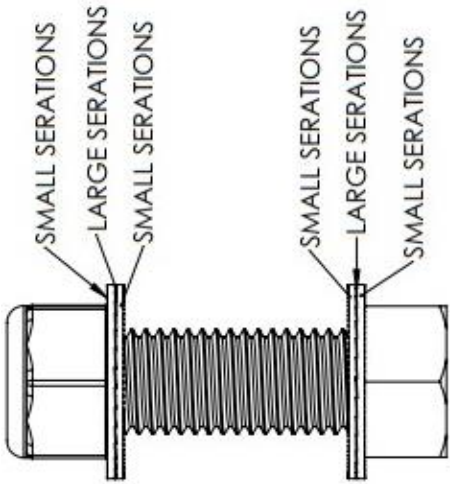

4C

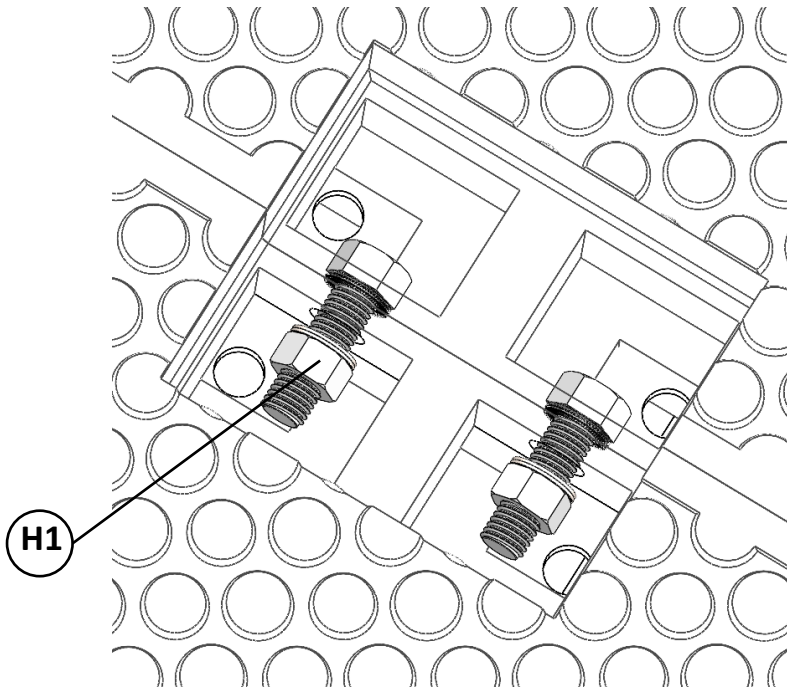

7A

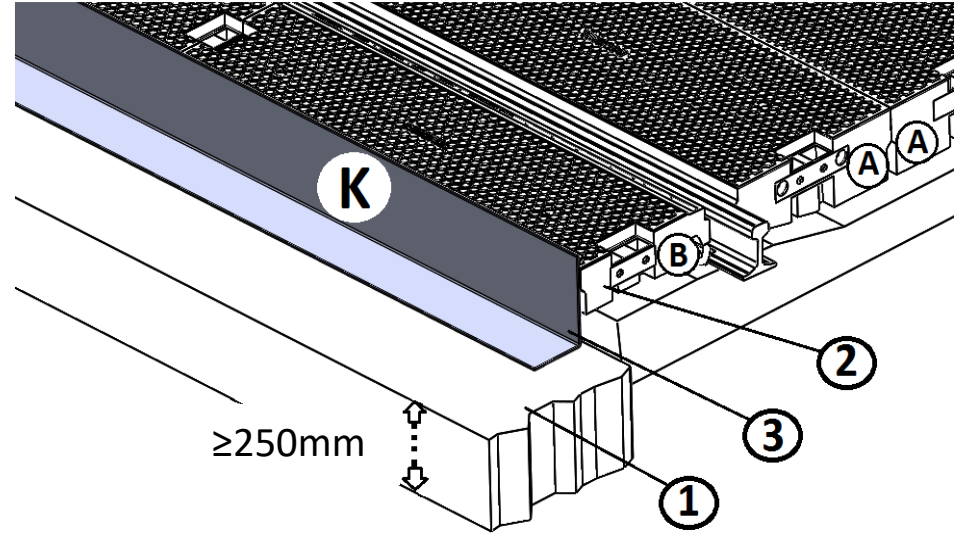

7B

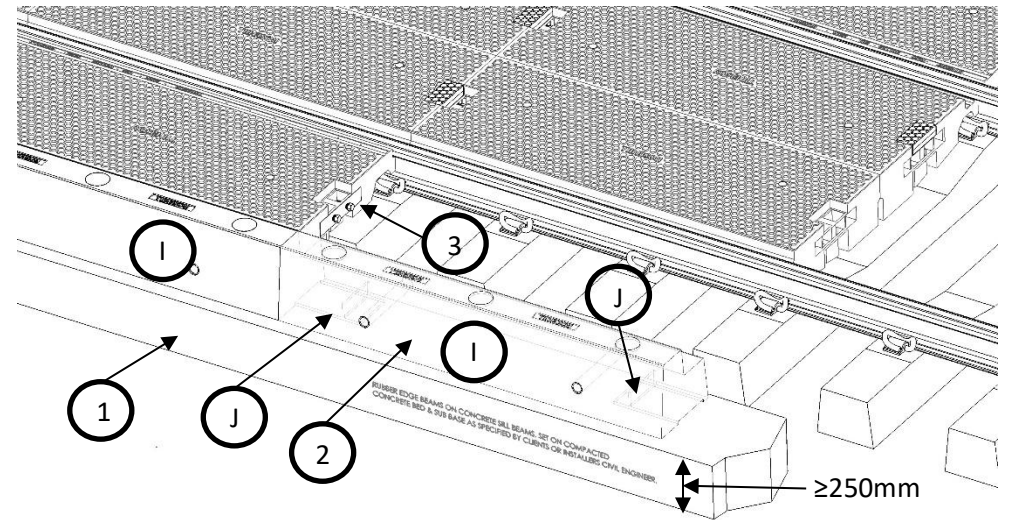

RUBBER EDGE BEAMS ON CONCRETE SILL BEAMS, SET ON COMPACTED CONCRETE BED & SUB-BASE AS SPECIFIED BY CLIENTS OR INSTALLERS CIVIL ENGINEER.

6

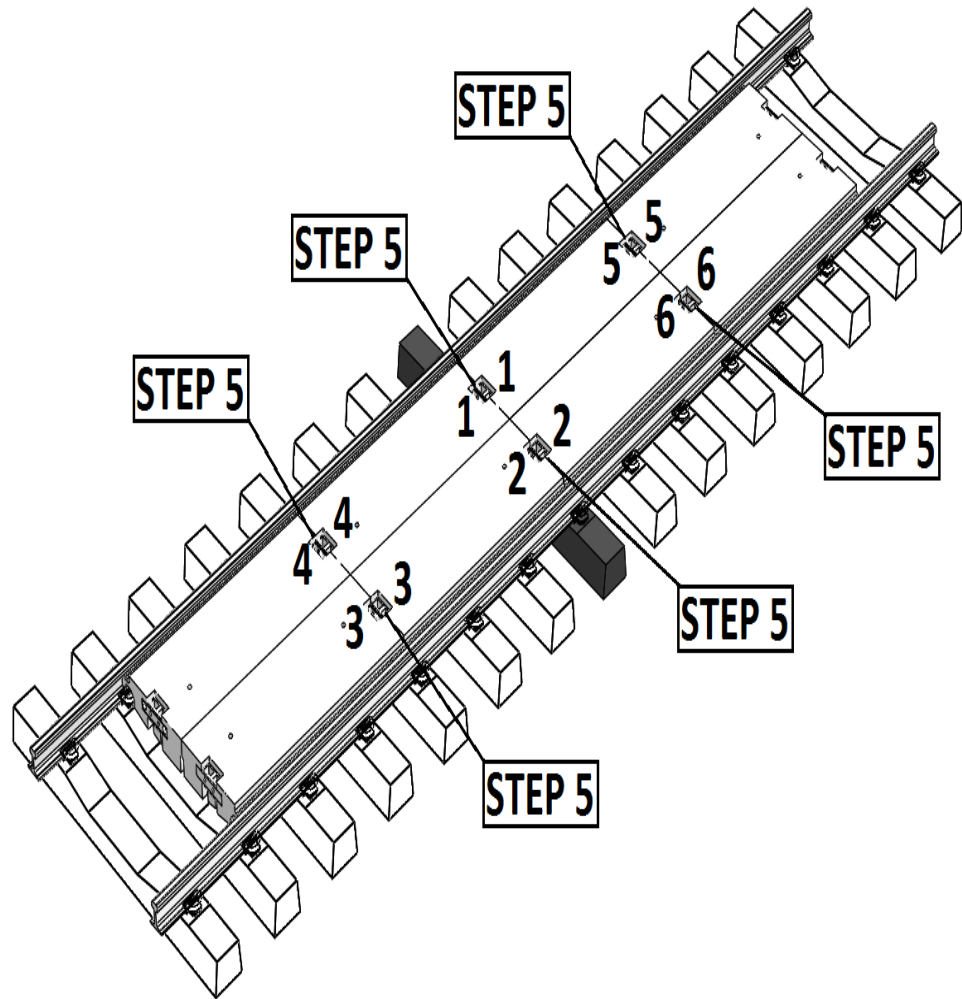

5 

