



Rosehill Rail



Walkway
Panels

Sustainable by Design



Modern rail infrastructure is rapidly evolving, with increased emphasis on sustainability, low carbon emissions, and resilience to climate changes. Sustainable infrastructure serves not only its primary engineering role but also benefits the community, environment, and economy. It helps to tackle key global challenges, including reducing consumption of non-renewable resources, minimising waste, and promoting energy conservation.

At Rosehill Rail, we've understood and embraced these demands for over three decades. We repurpose recycled tyre rubber using our unique low-energy cold-cure manufacturing process to produce innovative low-carbon products. These products, when used as replacements for traditional items made from virgin materials, such as concrete, wood, or even certain plastics, significantly reduce the overall carbon footprint, often resulting in a carbon negative solution.

While conventional materials like concrete will always have a place in the industry, Rosehill Rail work tirelessly developing solutions to replace these wherever possible. We offer a rapid offsite manufacturing process, incorporating sustainable and recycled materials.

More and more, we're seeing people move away from traditional materials and towards these zero-carbon solutions. Our eco-friendly products are being used instead of things like concrete crossing panels or asphalt speed cushions.



Safe & Sustainable Access

The Rosehill Walkway Panel presents a more secure, sustainable, and cost-effective alternative to conventional concrete paving blocks and aggregate-based footpaths.

As per the current standards outlined by Network Rail, a safe CESS access path requires a 100mm layer of Type 1 compacted material within a timber frame. However, the planning, administration, and cost associated with these standards can be complex, potentially leading to project delays and the need for post-completion inspections. By shifting to a lighter, more durable paving slab made from recycled rubber, we can simplify the process, reduce carbon emissions, and alleviate the maintenance concerns typical of traditional access paths.

This initiative significantly contributes to reducing reliance on concrete and aggregates, with the rubber slab playing a key role in lessening a project's carbon footprint. As a carbon negative solution that diverts tyre waste from landfills and replaces concrete, this innovation can compensate for carbon emissions from other parts of the project.

The estimated carbon benefits are as follows:

- Standard pathway using concrete slabs: 6kg carbon positive per slab (+0.006 tCo2e)
- Composite pathway: 11kg carbon negative per slab (-0.011 tCo2e)

With the reduction in bedding material, we anticipate a negative carbon impact of 22 tons for every 1Km of access walkways.



Product Information

Boasting a design life of over 40 years, walkway panels are not only durable but also reusable, further augmenting both the cost-effectiveness and CO2 savings achieved by avoiding the use of virgin materials. Walkway panels don't just serve immediate needs, but also prove beneficial in the long term, providing compounded savings both financially and environmentally over their lifetime.

Quick and safe to install

Non weather dependant install

Minimal ground prep with 40mm gravel foundation based upon GI and CBR of 2.5

Maintenance free, preventing weeds and rodents

Slip resistance with PSV 45

Flexibility within the design to create straight, curved or right angle footpaths



Product Information

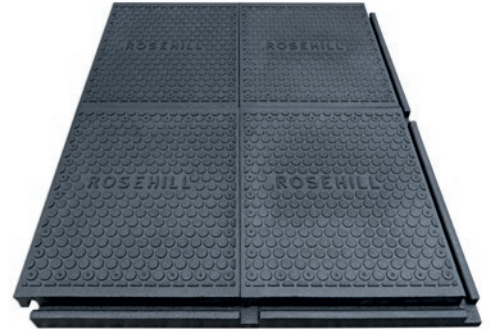
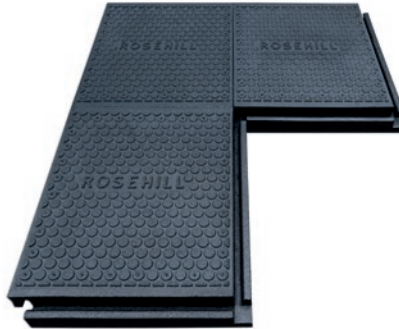
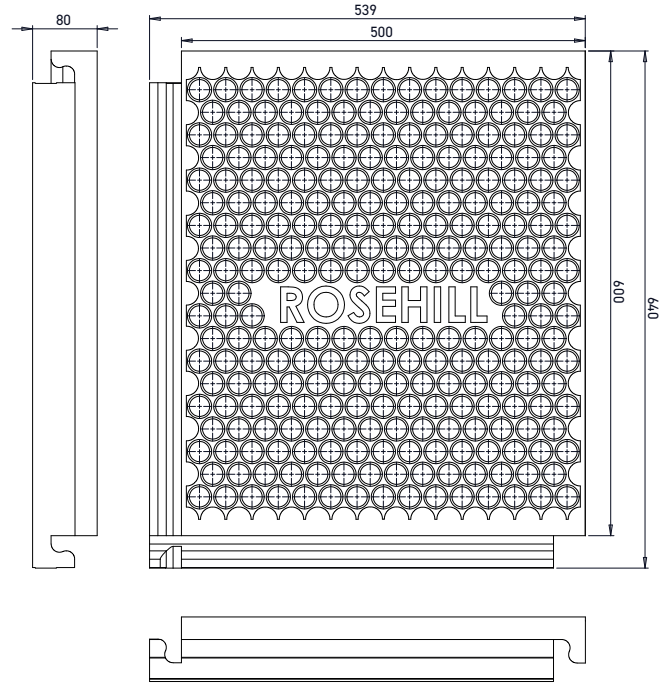
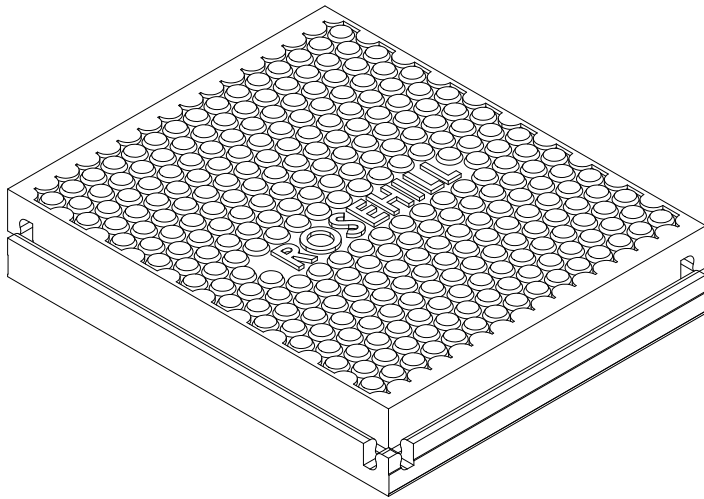

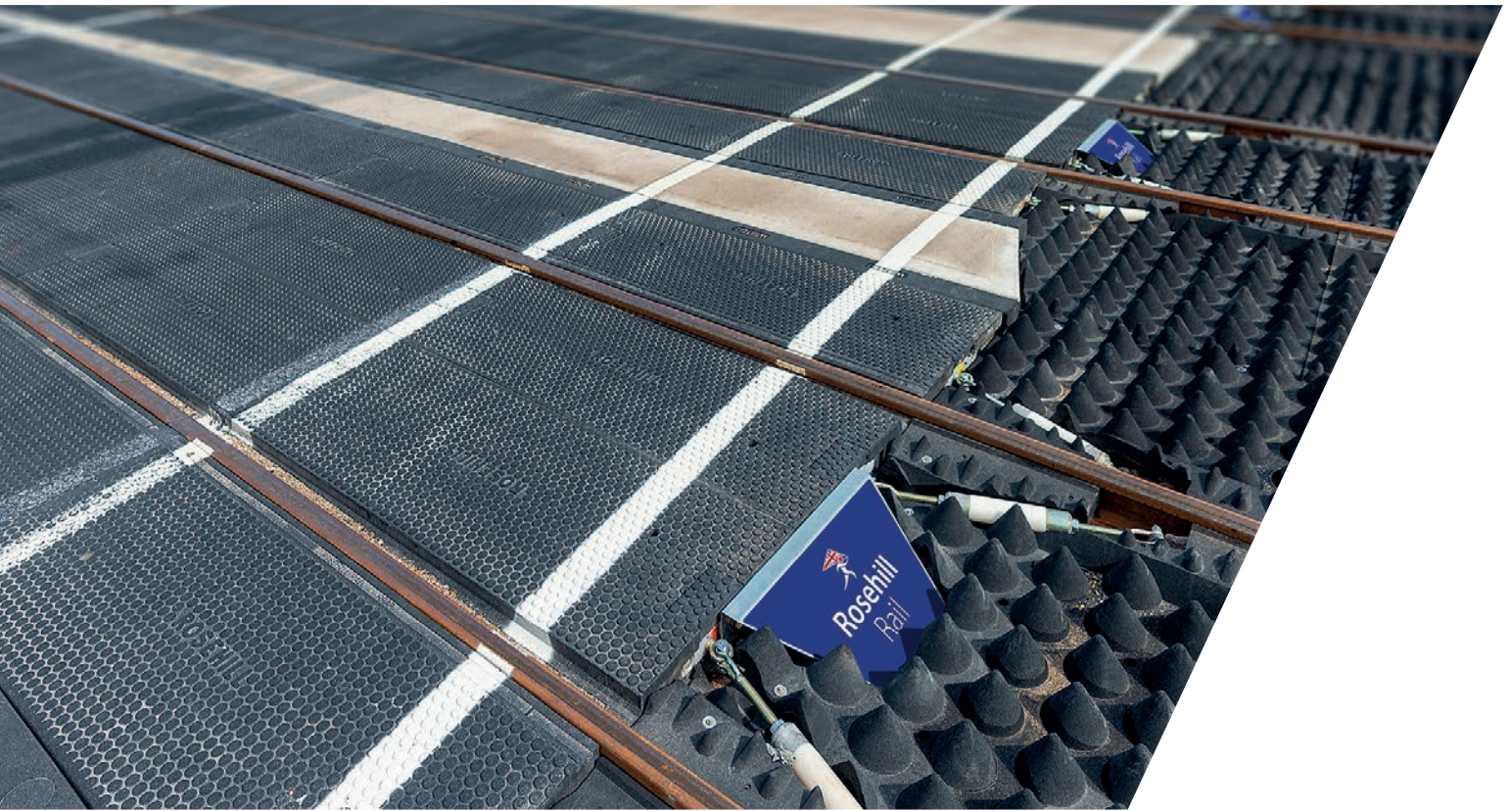

Centrally located in Sowerby Bridge, West Yorkshire, Rosehill Rail is perfectly situated to access significant motorway networks for prompt on-site deliveries or overseas shipments. Rosehill Rail's service and support is bolstered by over three decades of experience in polyurethane and rubber technology. This heritage has enabled us to accrue extensive industry knowledge, working in conjunction with global rail infrastructure companies and operators on a diverse array of projects.

Tailored to Your Specific Needs

Our products are produced at a specialised UK production facility equipped with automated production lines. Operated by our seasoned team, this setup allows us to maintain high production volumes even with short lead times. Our cold compression moulding process substantially reduces both manufacturing time and energy consumption. This makes our recycled rubber level crossing solutions not only a sustainable but also a cost-effective alternative to concrete.

Assured Quality

Adhering to the International Standard ISO9001:2008, Rosehill Rail operates a comprehensive quality assurance system. Audited annually by NQA (National Quality Assurance), our purpose-built equipment is specifically designed for manufacturing rubber rail crossing products and is meticulously maintained by specialist engineers. This commitment to quality underscores our dedication to delivering superior, reliable solutions for the rail industry.



ROSEHILL

ROSEHILL



INNOVATIVE RUBBER RAIL SOLUTIONS

Sustainably and efficiently manufactured in the UK from 100% recycled tyre rubber and bonded with our unique polyurethane chemistry, Rosehill Rail's solid rubber products are tough, durable, and engineered for long-term use.



**GET IN
TOUCH**



+44 (0)1422 839 610



info@rosehillrail.com



Beech Road, Sowerby Bridge,
West Yorkshire, HX6 2JT, UK

ROSEHILLRAIL.COM

